

UNDERGROUND UTILITY CROSSING

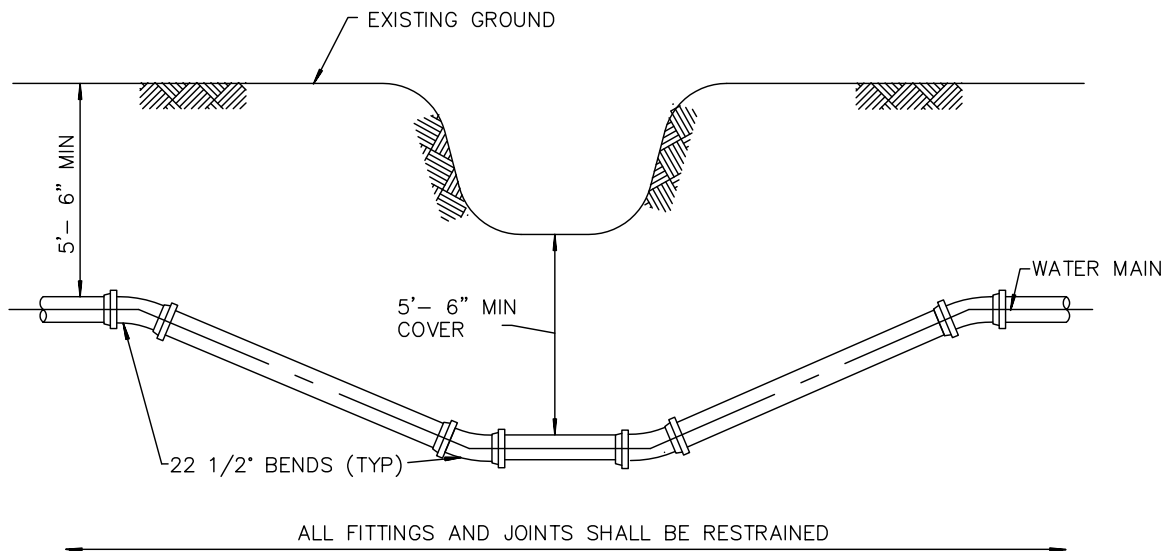

DITCH & STREAM CROSSING

NOTES:

Refer to other Standard Details for the remaining parts of the water main. Also, refer to the Contract Specifications. At no time are these details to supersede but rather to work in conjunction with other standards and specifications.

Unless otherwise indicated in a water main profile, water main shall be installed with a minimum cover of five (5) feet as measured from the permanent centerline elevation (or existing road elevation if the permanent pavement elevation is not known) or existing ground at water main, whichever results in a lower elevation. Where the water main crosses under other utilities a minimum clearance of eighteen (18) inches shall be maintained. Where the water main crosses under ditches a minimum clearance of five (5) feet shall be maintained. Where the water main dips under other utilities or ditches place 22.5° vertical bends and anchorages according to standard details. The Holland BPW prefers mechanical joint restraints. However, 350psi locking glands may be used.



CITY OF HOLLAND, MICHIGAN

Holland Board of Public Works

Water & Wastewater Department
625 Hastings Ave., Holland, MI 49423
Phone: (616) 355-1643 - Fax: (616) 355-1560
Director: John Van Uffelen, P.E.

WATER MAIN UTILITY CROSSING STANDARD DETAIL

DRAWN BY	SCALE	DATE
ARP	NONE	10-17-2006
APPROVED BY	SHEET	DWG FILE
DJS	WM-1	WM UTILITY XING.dwg